

METABUILDING 1st GROW / HARVEST CALL : MEET THE WINNERS !

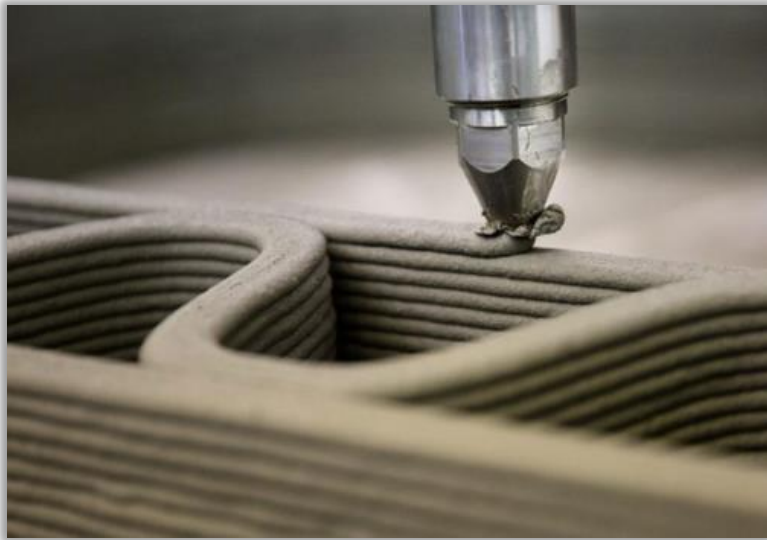

Unleashing the Innovation Potential of EU Construction SMEs

Construction + Additive Manufacturing Challenge



- Waste reuse through integration into large 3D printing processes for the construction sector
- Integration of new functionalities in construction components by means of 3D printing



METABUILDING Project has received funding from the European Union's Horizon 2020 Research and Innovation Programme under Grant Agreement No. 873964. The sole responsibility for the content of this document lies entirely with the author's view. The European Commission and the European Innovation Council and SME Executive Agency (EISMEA) are not responsible for any use that may be made of the information it contains.

METABUILDING 1st GROW / HARVEST CALL : MEET THE WINNERS !

Recycled 3D Staircase

A Highly Customized Robotically Manufactured 3D Printed Staircase

SECTORS INVOLVED : Construction · Additive Manufacturing · Circularity & Recycling

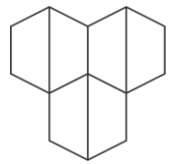

hyperion
robotics

FINLAND

iaac

Institute for
advanced
architecture
of Catalonia

BARCELONA

SPAIN

"This unique opportunity will increase our technological capabilities, helping us solve some practical and big challenges that the concrete industry face. The combination of our automation and optimization technology (3D printing) and the use of sustainable materials, are key to revolutionizing one of the least automated industries, and this project will be an important milestone for us to get there."

Fernando De los Rios
Co-founder & CEO
Hyperion Robotics



"Thanks to the METABUILDING project, we are able to develop state-of-the-art technology in IOT and robotics that Enable 3D printing of building parts from recycled materials, transitioning towards a more green and digital construction industry."

Alexandre Dubor
Head of Fabrication & Robotics
IAAC

Team

Hyperion Robotics + Institute for Advanced Architecture of Catalonia (IAAC)



Experts in concrete 3D printing, with know-how in :

- 3D printing concrete made of geopolymers and recycled material
- Automation and control of the extruder and the pump
- Automation of cable placement within the 3D printed layer



Experts in sustainable architecture and digital fabrication, with know-how in

- 3D Printing with clay mortar and natural material
- 3D scanning and sensor analysis for 3D Printing
- Real time control of robot for 3D printing

3D Printed outdoors slope stairs



Precast slope stairs

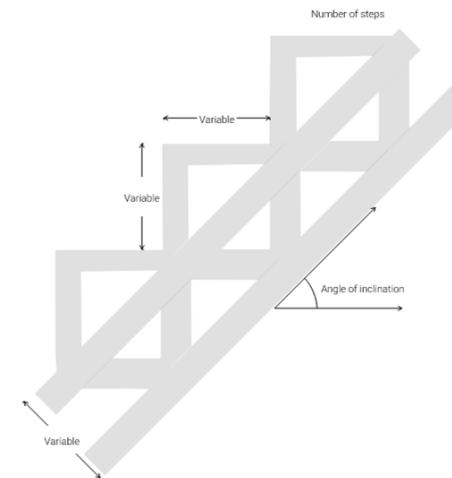

3D-Printed slope stairs

Industry market :

After interviewing concrete precast industry leaders (Luja Betoni, Rudus, Topwerk), we discovered that 3D-Printing offers novel opportunities for manufacturing outdoors slope stairs:

- Slope stairs are supported by a hill - do not require reinforcement
- Slopes and sizes of hills vary greatly - many can't be produced from an adjustable mold

3D printed solution :

- Completely customizable
- Requires only 2 people to produce
- Requires less than 1 hour to print
- Material is printed in a structurally efficient way (lattice beam) - up to 70% material saved
- Up to 97% upcycled mortars - Low CO2 footprint

Up to 97% upcycled mortars



New opportunities from research in geopolymer :

- Binder and aggregate are upcycled from industrial waste from mining, steel industry, coal plants and demolition.
- Up to 80 MPA compressive strength
- Cement-based mortar - up to 70% recycled - 90 kg of CO₂/ton
- Alkali activated mortar - up to 97% recycled - 15 kg of CO₂/ton

Inconsistent output when extruding upcycled mortars

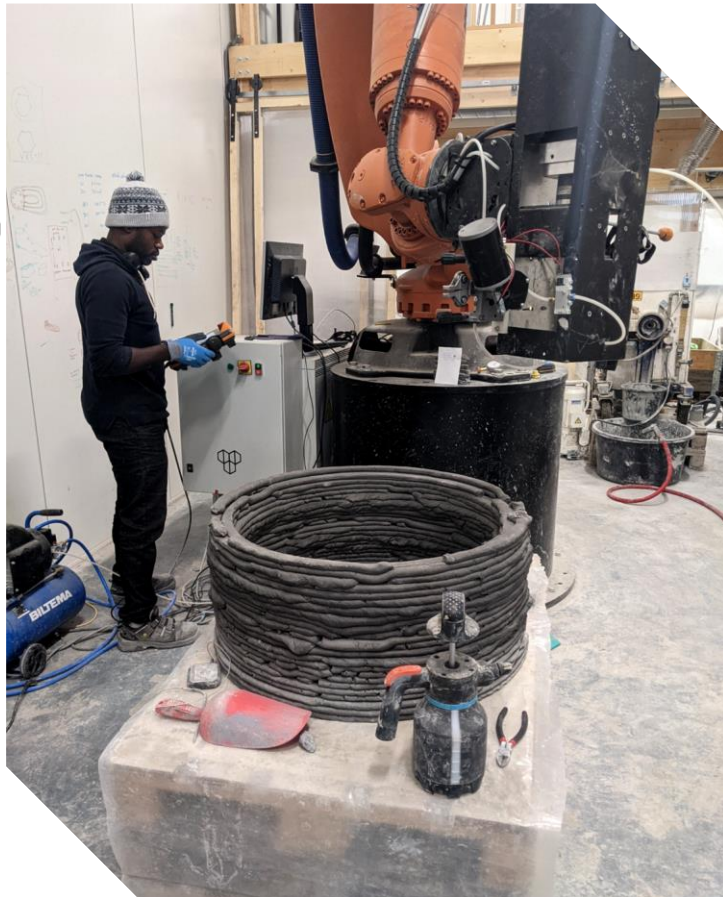

Alkali-activated just add water mortar



Mortar based on paper-pulp industry waste product



Mortar based on cement and steel industry waste products

Monitoring opportunities

MATERIAL
CONSISTENCY

x

ROBOT
SPEED

EXTRUDER
FEED

x

=

PRINT
WIDTH

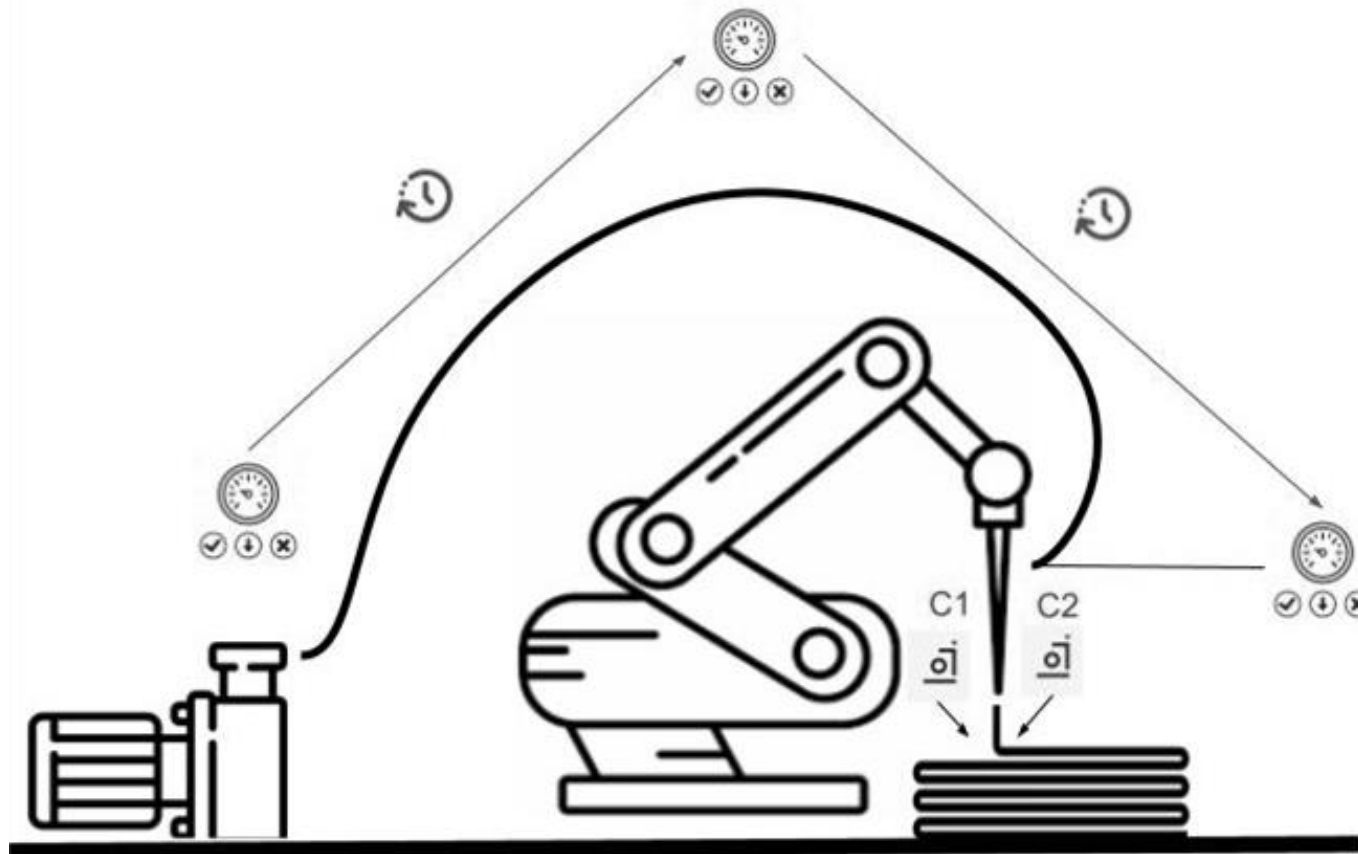

Printing width variation caused by:

- Material Inconsistencies
- Pump worn out
- Weather conditions.
- Geometry (intersection / double lines / corner)
- Path acceleration and deceleration ?

Digital control possible on

- Robot speed
- Extruder feed

Support



METABUILDING Project

We believe that the Metabuilding project is a unique opportunity for us to increase our technology capabilities, which will help us solve some practical and big challenges that construction and the concrete industry face. The combination of our automation and optimization technology (3D printing) and the use of sustainable materials, are key to revolutionizing one of the least automated industries and this project will be an important milestone for us to get there.

**Fernando De los Rios Co-founder and
CEO at Hyperion Robotics**

Thanks to the Metabuilding project, we are able to develop state of the art technology in IOT and robotics that enable 3D printing of building parts from recycled materials, transitioning towards a more green and digital construction industry.

**Alexandre Dubor, Head of Fabrication
and Robotics at IAAC.**

Funding

This innovation project receives funding in the framework of the METABUILDING project funded through the H2020-INNOSUP programme directed by the European Innovation Council and SMEs Executive Agency (EISMEA).
Grant agreement 873964.



Thank you for your kind attention

Project :

www.metabuilding-project.eu



Platform :

www.metabuilding.com



METABUILDING Project has received funding from the European Union's Horizon 2020 Research and Innovation Programme under Grant Agreement No. 873964. The European Commission and the European Innovation Council and SME Executive Agency (EISMEA) are not responsible for any use that may be made of the information it contains. The sole responsibility for the content of this document lies entirely with the authors.